

**INSTALLATION INSTRUCTION, PARTS LIST
AND CONFIGURATION GUIDE**

FOR THE

COKE TEA DISPENSER (TEA URN)
Dispenser Model No. 925



Intertek
3158001
CONFORMS TO
NSF STD 18

NOTICE:

The information contained in this document is subject to change without notice.

SCHROEDER AMERICA MAKES NO WARRANTY OF ANY KIND WITH REGARD TO THIS MATERIAL, INCLUDING, BUT NOT LIMITED TO, THE IMPLIED WARRANTIES OF MERCHANTABILITY AND FITNESS FOR A PARTICULAR PURPOSE. SCHROEDER AMERICA shall not be liable for errors contained herein or for incidental consequential damages in connection with the finishings, performance, or use of this material.

This document contains proprietary information which is protected by copyright. All right reserved.

© Copyright 2015 by Schroeder America, all rights reserved.

THIS DOCUMENT CONTAINS IMPORTANT INFORMATION
This manual must be read and understood before the installation and operation of this dispenser.

Schroeder America
5620 Business Park • San Antonio, TX 78218
210.662.8200 • Fax: 210.667.2600 • www.schroederamerica.com
Toll-Free 877.404.2488

1. DISPENSER DIMENSIONS AND WEIGHT

- A. Single valve dispenser weight is 13 lb.
- B. Single valve shipping weight is 15 lb.

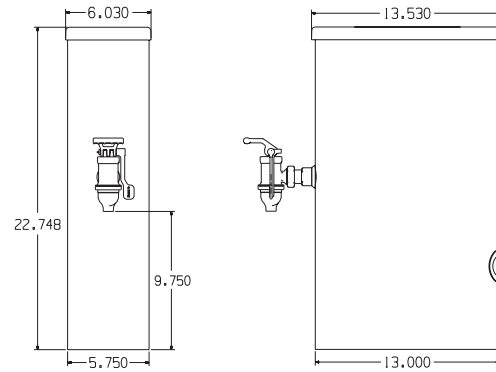

- C. Double valve dispenser weight is 14 lb.
- D. Double valve shipping weight is 20 lb.

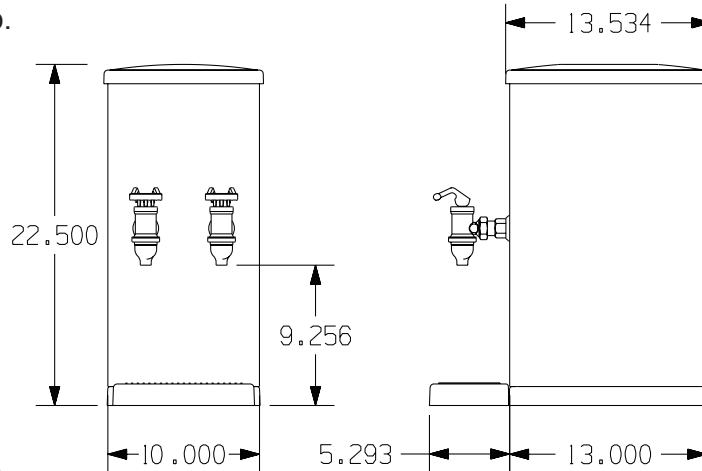

2. WATER AND SYRUP REQUIREMENTS

	<u>Minimum</u>	<u>Maximum</u>
Water/Soda	40 PSIG (2.8 kg/cm ²)	110 PSIG (7.73 kg/cm ²)
Syrup (Sugar)	20 PSIG (2.8 kg/cm ²)	70 PSIG (4.92 kg/cm ²)
Water/Soda	10 PSIG (2.8 kg/cm ²)	70 PSIG (4.92 kg/cm ²)

3. INSTILLATION

Water pipe connections and fixtures directly connected to a potable water supply shall be sized, installed and maintained in accordance with federal, state and local codes.

IMPORTANT

THIS EQUIPMENT TO BE INSTALLED WITH ADEQUATE BACKFLOW PROTECTION.

- A. The single oval tea urn may only be installed loose on the countertop or mounted to the countertop with the fastener package which is comprised of the following parts: (Kit # 670-0013)
 1. 4 only, P.N. 233-0004, Bolt, 10-24
 2. 4 only, P.N. 239-0001, Spacer
 3. 8 only, P.N. 243-0028, Nut, Hex, 10-24
 4. 4 only, P.N. 240-0017, Washer, Flat
- B. Attach the bolts to the inner support bracket using a washer and nut. Tighten the nut to keep the bolt firmly attached to the inner bracket.
 1. For additional mounting options, see Base/Drip Tray Accessories page.

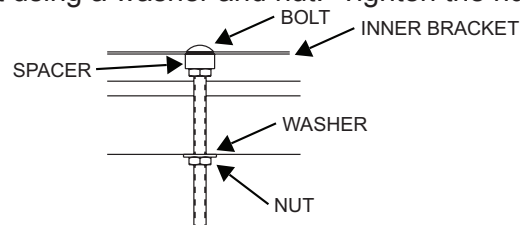

- C. Using the template, locate the desired position of the urn and mark the center of the holes on the counter. Drill holes using 13/64 drill bit.
- D. Set urn on counter so that bolts protrude through holes.
- E. Mounting to counter:

NOTE:

To comply with National Sanitation Foundation (NSF) requirements with the United States, unit base must be sealed to the countertop.

- 1. Liberally apply Silastic® sealant (such as Dow Corning RTV 730 or equivalent) on base bottom edge.

NOTE:

DO NOT move unit after positioning, or the seal from base to counter will be broken.

- 2. Apply additional sealant around bottom of base. Seal must have a minimum 1/2" radius to prevent crevices and to ensure a complete seal.
- 3. Allow sealant to dry to MFG recommendations.
- F. Assemble washers and nuts to bolts from underneath the countertop. Tighten firmly. DO NOT OVER TIGHTEN!
- G. Using a right angle beverage fitting supplied in the install kit, attach inlet water and concentrate tubes to the back of the flow control modules. Tubing can be routed either through a hole in the countertop or through the access point in the back of the urn. (Be sure to use proper size hose clamps to secure tubing to inlet fittings).

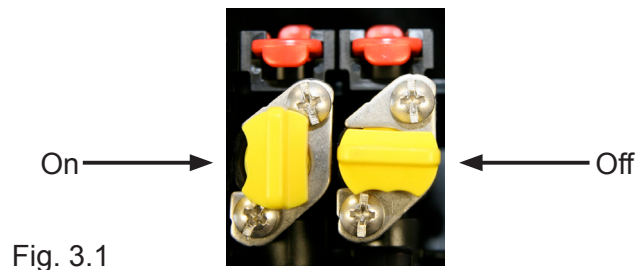

Fig. 3.1

NOTE:

Be sure to lock inlet line fitting into FCM/MM module assembly using the red retainers before introducing product and water.

- H. See above
- I. Turn on water and syrup at source.
- J. Turn on water and syrup to flow controls by rotating yellow Shut-off knobs (see Fig. 3.1).
- K. Check for leaks.
- L. Remove nozzle and install ratio separator.
- M. Dispense about two (2) cups and dispose. Using a ratio cup check ratio. If not in spec use a small screwdriver to adjust. Clockwise increases flow. Counterclockwise decreases flow.
- N. Unit is now operational.

4. RATIO/BRIX

The Schroeder America Dispenser has been thoroughly tested and sanitized prior to shipment. The installer will be required to ratio/brix the dispenser. A Schroeder America Dispenser syrup separator or refractometer may be used.

NOTE:

Sugar free products require a syrup separator. Installer must cool or chill the product before brixing the system. Ratio will be different between cold product and warm product.

IMPORTANT

BEFORE RATIO/BRIXING SYSTEM, PURGE PRODUCT AND WATER THROUGH THE TEA URN DISPENSER TO ENSURE PROPER PRODUCT TEMPERATURE.

- A. To adjust water flow rate, turn off syrup side by rotating the yellow Shut-off, then pull handle to purge any remaining tea concentrate until clear liquid is dispensed. Capture water in a graduated cylinder (oz.) or measuring cup while timing the dispense. Divide the volume (oz.) of water by the time. This will equal the flow rate.

NOTE:

The Schroeder America Tea Dispenser is designed to flow 2.4oz/sec. or 12oz/5 sec. This is the proper setting for 5:1 ratio.

- B. To adjust flow control assembly, remove the red cap to expose the slotted yellow adjustment screw (Fig. 4.1). To regulate flow, turn clockwise to increase flow and counterclockwise to decrease flow. If the flow control assembly contains a slotted green adjustment screw, it is mechanical. To regulate flow, turn counterclockwise to increase flow and clockwise to decrease flow (opposite flow control).

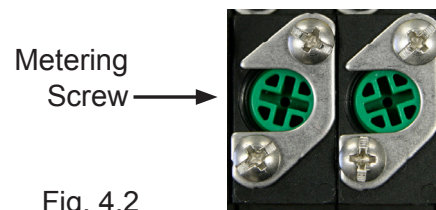
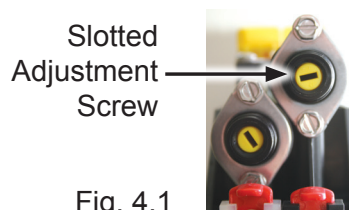

- C. To achieve the proper water flow rate, adjust the yellow/green screw within the flow control module. For the mechanical application adjust the green metering screw (Fig. 4.2).

NOTE:

Depending on the pressure of the incoming plain water, the maximum flow may not be achievable. There are two solutions to this problem.

- 1) Use slower flow rate. This will require ratio/brix adjustment.
- 2) Add a water booster to the system.

- D. To Ratio/Brix the final product, remove dispensing nozzle from valve.
E. Replace dispensing nozzle with the Schroeder America syrup separator nozzle. Rotate the separator in position to ensure seal against the diffuser.
F. Adjust syrup flow to required ratio.

5. CLEANING AND SANITIZING

The Schroeder America Dispenser is shipped from the factory cleaned and sanitized in accordance with NSF guidelines. The dispenser must also be cleaned and sanitized after installation is complete. It is recommended that the operator provide continuous maintenance as required by the manual and/or state and local guidelines to ensure proper operation.

A. External/Internal Cleaning Solutions:

Cleaners (ivory liquid, calgon, etc.) should be mixed with clean potable water at a temperature of 90 to 110 degrees F. The acceptable mixture ratio is one ounce of cleanser to two gallons of water. Any NSF approved equivalent cleaner may be used. Rinsing must be thorough using clean potable water.

B. Internal Cleaning:

1. Remove top cover.
2. Wipe inside of the Tea Urn with a clean cloth mixed with the cleaner.
3. Inspect to make sure any product residue has been removed.
4. Dry with a clean soft cloth.

IMPORTANT

ONLY USE INTERNAL CLEANING SOLUTIONS THAT ARE APPROVED FOR BEVERAGE DISPENSER APPLICATIONS, SUCH AS BevClean™. (NO CAUSTIC CHEMICALS SUCH AS INDUSTRIAL KITCHEN CLEANING CHEMICALS SHOULD EVER BE USED)

C. External Cleaning:

The stainless steel urn can be cleaned by wiping with a cloth soaked with warm cleansing detergent. Inspect the hose to ensure all residue is removed. Abrasive cleaning or scouring pads should not be used as they will scratch the urn finish.

NOTE:

It is recommended that the nozzle be removed and cleaned daily.

D. Sanitizing:

Cleaning and Sanitizing are not required for potable water circuits. The potable water lines should remain connected during the cleaning procedures for the concentrate circuits to avoid contamination.

1. Disconnect concentrate container from product line.
2. Attach product line to container containing sanitizing solution mixed to mfg. recommendations (50 ppm is recommended)
 - a. Using yellow Shut-off, turn incoming water off.

NOTE:

Sanitizing solution temperature should be between 70° to 100° F (max).

3. Prepare enough solution to sanitize from the concentrate source to the tea urn dispenser.

NOTE:

Alternate - using a fitment removed from a bag in box container. Attach fitment to concentrate fitting. Prepare sanitizing solution in a container and set fitment/fitting assembly in solution.

4. Pull tea urn dispenser handle, solution will begin to flow towards dispensing valve.

5. When color turns clear, concentrate line is full of sanitizer solution.
6. Wait 15 minutes.
 - a. Reconnect concentrate product line.
7. Purge sanitizer from line with concentrate product.
8. Purge until concentrate is flowing from dispensing valve.
9. Using yellow Shut-off, turn incoming water on.
10. Taste the beverage to verify that there is no off taste.

WARNING

FLUSH SANITIZING SOLUTION FROM CONCENTRATE LINE AS INSTRUCTED. RESIDUAL SANITIZING SOLUTION LEFT IN SYSTEM COULD DAMAGE LINES AND DISPENSER PARTS. IT MAY ALSO CREATE A HEALTH HAZARD.

6. TROUBLE SHOOTING

- A. No water dispensed
 - Check water supply
 - Check Shut-off (is it open)
 - Check ratio/brix adjustment
 - Line plugged
- B. No syrup dispensed
 - Check CO₂ pressure
 - Check for product
 - Check Shut-off
 - Check ratio/brix adjustment
 - Line plugged
- C. Weak product taste
 - Check ratio/brix adjustment
 - Check for plugged line
 - Check Shut-off - completely open
 - Check syrup supply
- D. Strong product taste
 - Check ratio/brix adjustment
 - Check syrup CO₂
 - Check water supply

ACCESSORIES

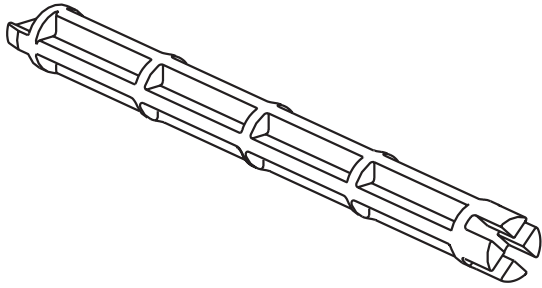

SHUT-OFF TOOL
P.N. 316-0005

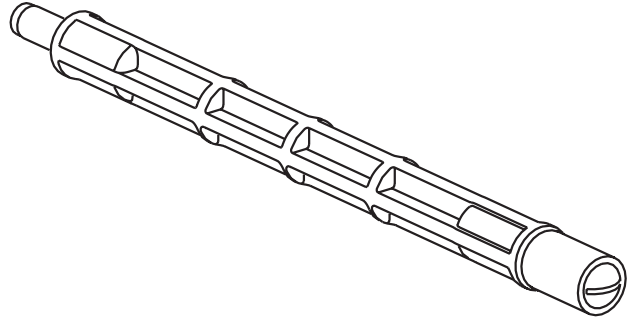

FLOW CONTROL TOOL
P.N. 316-0006

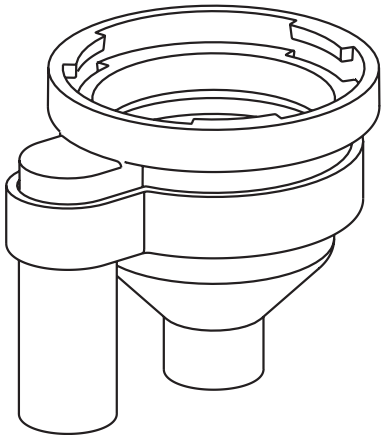

SEPARATOR
P.N. 316-0010

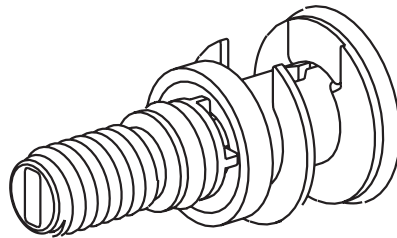

KIT, MECHANICAL CONTROL
P.N. 675-0005

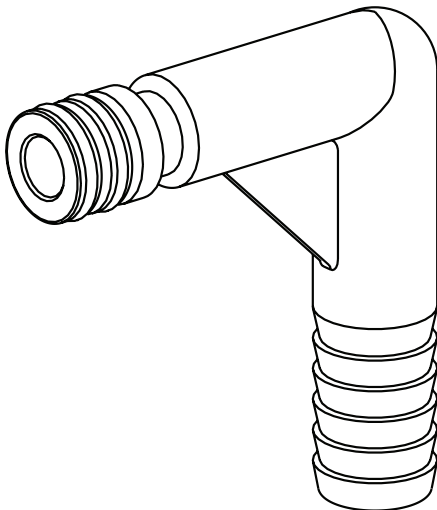

3/8 90 DEG BARB. FITTING
P.N. 626-0013

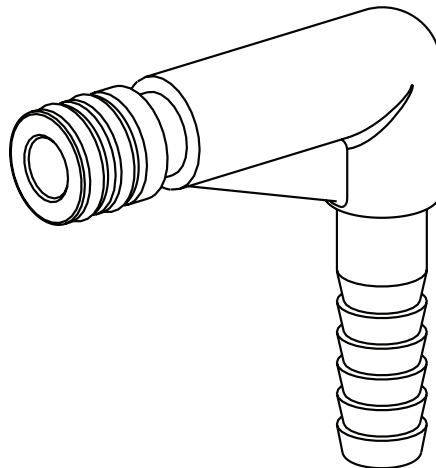

1/4 90 DEG BARB. FITTING
P.N. 626-0012

OVAL CAN ASSEMBLY

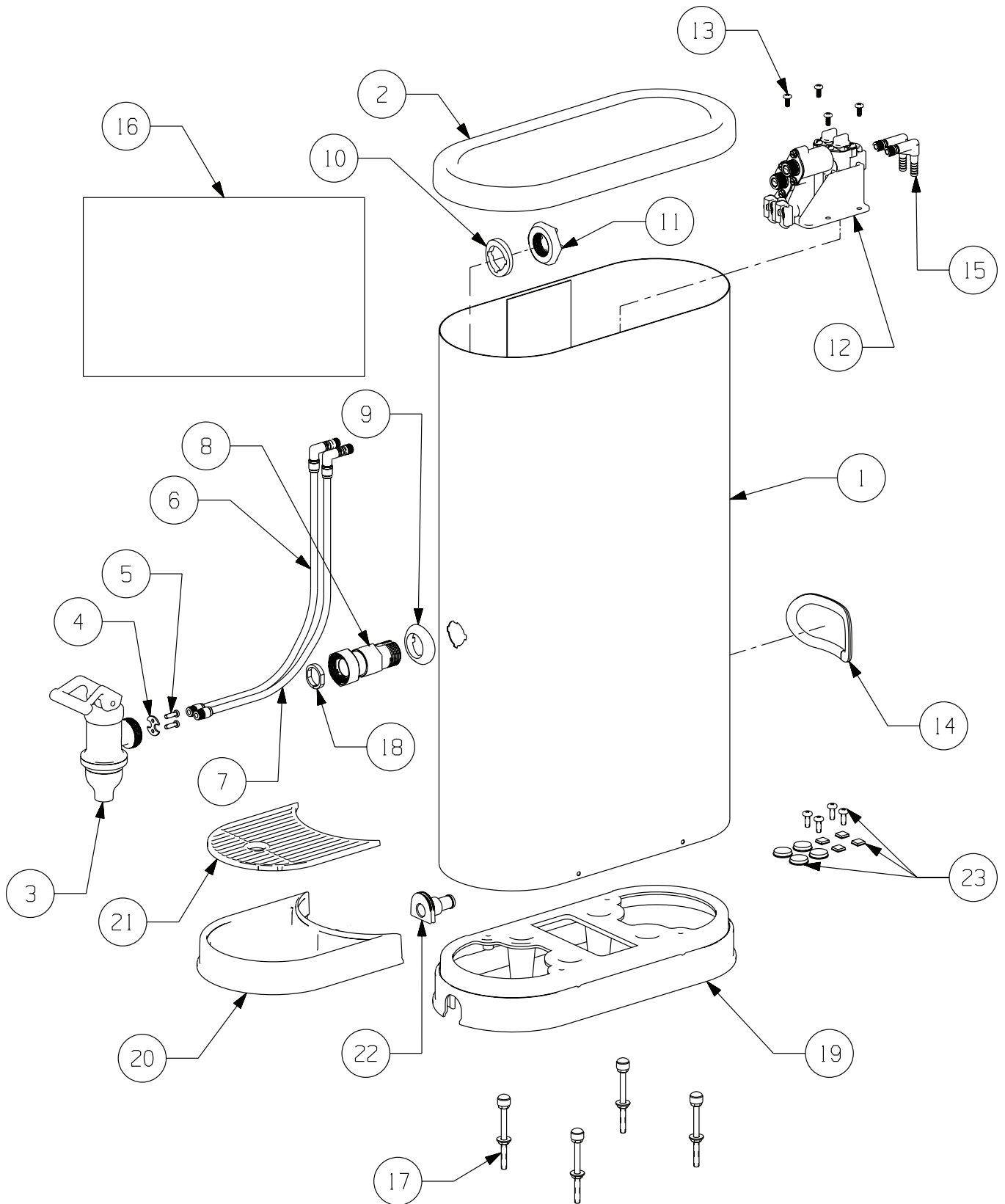

OVAL CAN ASSEMBLY

OVAL ASSEMBLY		
ITEM	SCHROEDER PN	DESCRIPTION
1	634-0105	CAN ASSY, COKE TEA
2	265-0350	LID, OVAL, 5.75"
3	637-0015	ASSY, VALVE, POSTMIX,W/O ADA LEVER
4	256-0021	PLATE, VALVE, TEA
5	224-0006	SCREW, 6-19x.500, PLASTITE, PH, PHD
6	632-0143	SUB-ASSY, WATER, PMV W/O ADA LEVER
7	632-0144	SUB-ASSY, S1, PMV W/O ADA LEVER
8	645-0173	SHANK ASSY, PMV
9	265-0374	SPACER, PMV TO 5.75" CAN
10	265-0377	SPACER, INSIDE, 5.75" CAN
11	265-0382	NUT, HEX, 1-16, NYLON
12	660-1003	VALVE/BRACKET ASSY, 2V, BLK, TEA
13	220-0037	SCREW, 8-32x.375, PH, PHD, 18-8SS
14	210-0030	GROMMET,CAN,BACK,TEA
15	670-0033	PKG, INSTALL, 2 EA 1/4 BARB 90 DEG FITTINGS
17	670-0013	PACKAGE,INSTALL,SCREWS,TEA URN - FOR MOUNTING TO COUNTER WITH NO BASE
18	210-0046	GASKET,SHANK,PM VALVE
19	265-0544	BASE,TEA,SINGLE
20	631-0132	DRIPTRAY ASSY,1V,W/DRAIN,REMOVABLE CUPREST
21	265-0550	CUPREST,DRIPTRAY,1V TEA
22	675-0062	KIT,DRAIN ADAPTER,DRIPTRAY,TEA
23	675-0081	KIT,BUMPERS & SCREWS
AVAILABLE GRAPHICS		
16	812-0100	GRAPHICS, TEA URN - GOLD PEAK TEA 1V
16	812-0102	GRAPHICS, TEA URN - FUZE ICED TEA
AVAILABLE ACCESSORIES		
	670-0030	PKG, INSTALL, 2 EA 3/8 BARB 90 DEG FITTINGS
	675-0059	KIT,ROUND FEET AND SCREWS FOR BASE,TEA
	675-0060	KIT,SQUARE FEET FOR DRIPTRAY,TEA
OTHER AVAILABLE KITS		
	675-0042	KIT, RETAINER, & SCREWS, PMV : ITEMS 4 AND 5
	675-0082	KIT, POSTMIX VALVE W/O ADA LEVER : ITEMS 3, 4, AND 5
	675-0044	KIT, SHANK ASSY, PMV: ITEMS 8, 9, 10, AND 11

SQUARE CAN ASSEMBLY

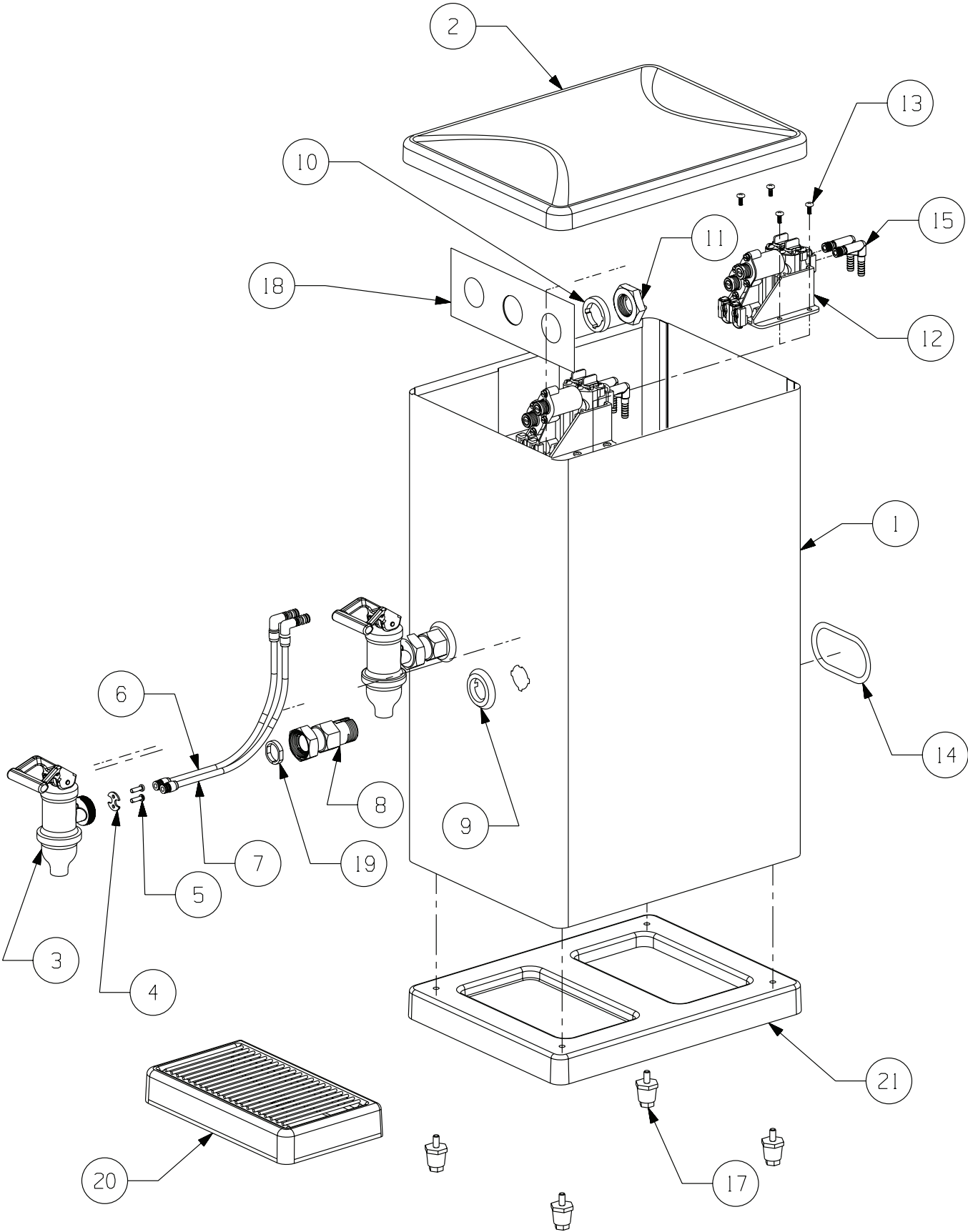

SQUARE CAN ASSEMBLY

SQUARE ASSEMBLY		
ITEM	SCHROEDER PN	DESCRIPTION
1	663-0002	FRAME ASSY, WELDED, SQUARE URN, 2V
2	265-0445	LID, 2V SQUARE, TEA
3	637-0015	ASSY, VALVE, POSTMIX, W/O ADA LEVER
4	256-0021	PLATE, VALVE, TEA
5	224-0006	SCREW, 6-19x.500, PLASTITE, PH, PHD
6	632-0113	SUB-ASSY, WATER, SQ URN, PMV
7	632-0114	SUB-ASSY, S1, SQ URN, PMV
8	645-0173	SHANK ASSY, PMV
9	265-0385	SPACER, PMV TO SQUARE CAN
10	265-0386	SPACER, INSIDE, PMV TO SQUARE CAN
11	265-0382	NUT, HEX, 1-16, NYLON
12	660-1003	VALVE/BRACKET ASSY, 2V, BLK,
13	220-0037	SCREW, 8-32x.375, PH, PHD, 18-8SS
	220-0019	SCREW, 8-32x.500, PH, PHD, 18-8SS (FOR 3RD VLV ASSY)
14	210-0030	GROMMET, CAN, BACK
15	670-0034	PKG, INSTALL, 4 EA 3/8 X 1/4 90 DEG
	670-0035	PKG, INSTALL, 6 EA 3/8 X 1/4 90 DEG
17	234-0003	LEG, PLASTIC, BLACK, ADJUSTABLE
18	319-0578	PLATE, 2V/3V SQ TEA URN
19	210-0046	GASKET, SHANK, PM VALVE
20	675-0073	KIT, DRIP TRAY, 2V SQ TEA
21	265-0447	BASE, 2V SQUARE, TEA
AVAILABLE GRAPHICS		
	812-0101	GRAPHICS, TEA URN - GOLD PEAK TEA 2V
AVAILABLE ACCESSORIES		
	670-0031	PKG, INSTALL, 4 EA 3/8 X 3/8 90 DEG
	670-0032	PKG, INSTALL, 6 EA 3/8 X 3/8 90 DEG
OTHER KITS AVAILABLE		
	675-0042	KIT, RETAINER, & SCREWS, PMV : ITEMS 4 AND 5
	675-0043	KIT, POSTMIX VALVE : ITEMS 3, 4, AND 5
	675-0044	KIT, SHANK ASSY, PMV: ITEMS 8, 9, 10, AND 11

FLOW CONTROL ASSEMBLY

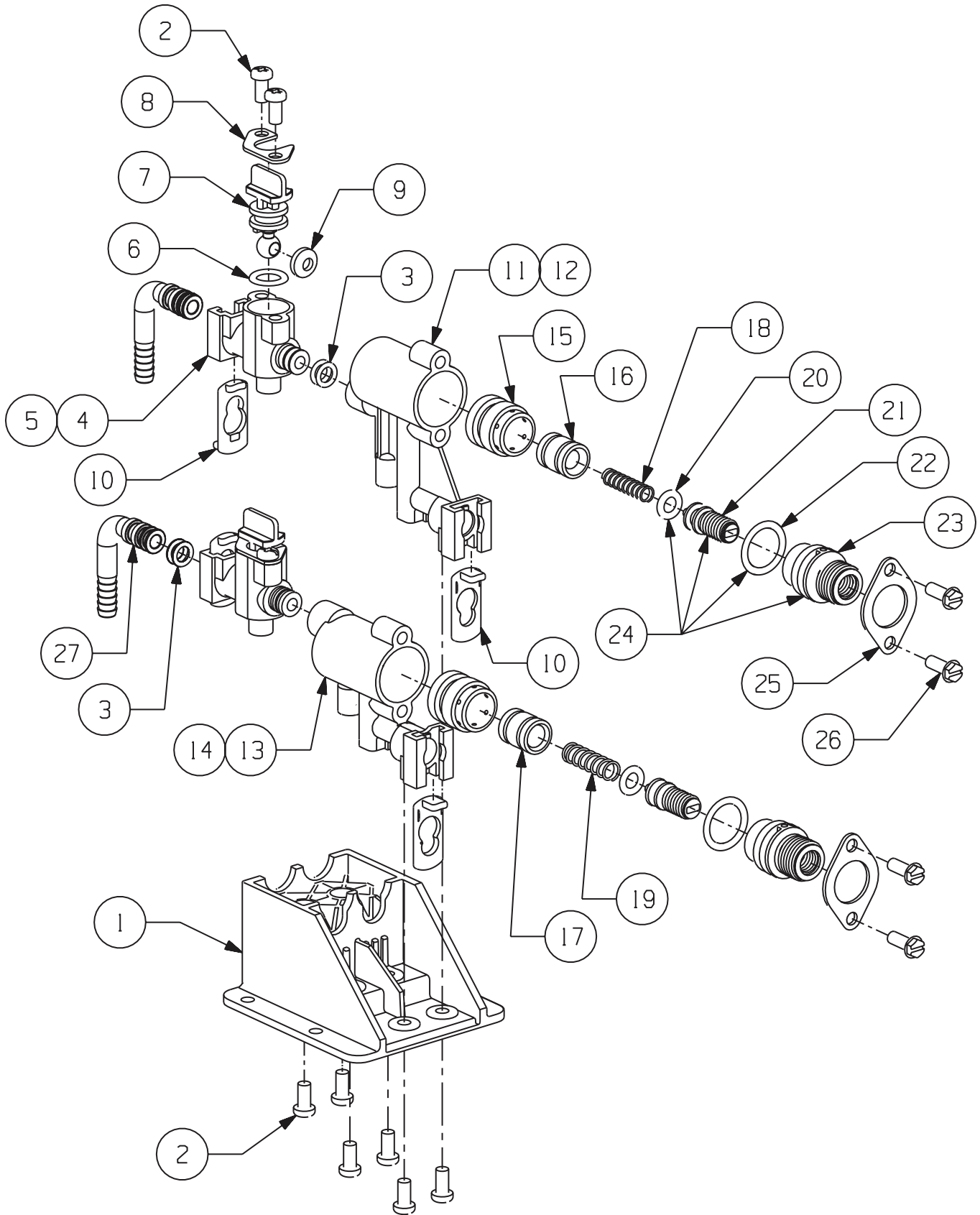

FLOW CONTROL ASSEMBLY

FLOW CONTROL ASSEMBLY		
ITEM	SCHROEDER PN	DESCRIPTION
1	265-0362	BRACKET,MTG, VALVE, TEA
2	224-0002	SCREW, 8-16x.375, PLASTITE, PHSL, PHD
3	208-0010	O-RING, 2-010
4	625-0034	BACKBLOCK SUB-ASSY, BLACK - WITH 208-0010
5	637-0003	ASSY, VALVE, BACKBLOCK, BLACK - COMPLETE
6	208-0110	O-RING, 2-110
7	625-0009	STEM ASSY, SHUT-OFF - WITH 208-0110
8	256-0011	RETAINER, STEM
9	265-0043	WASHER, STEM
10	265-0063	RETAINER, CLIP, FITTING
11	639-0030	ASSY, FLOW CTRL, SYRUP, BLK, TEA
12	631-0033	SUB ASSY, BODY, FLOW CTRL, SYRUP,1, BLK
13	639-0029	ASSY, FLOW CONTROL, WATER, NAT W/ BLK BONNET
14	631-0017	SUB ASSY, BODY, FLOW CONTROL, 2, NAT
15	277-0001	SLEEVE, WATER/SYRUP
16	277-0008	PISTON, SYRUP, .088
17	277-0010	PISTON, WATER, .140
18	215-0002	SPRING, SYRUP
19	215-0003	SPRING, WATER
20	208-0108	O-RING, 2-108
21	625-0035	PLUG ADJUSTER SUBASSY,YELLOW,TEA - WITH 208-0108
22	208-0114	O-RING, 2-114
23	625-0007	BONNET SUB-ASSY, BLACK - WITH 208-0114
24	631-0078	PLUG ADJUST ASSY, BLACK W/ YELLOW PLUG
25	256-0010	RETAINER, BONNET
26	224-0001	SCREW, 8-16x.500, PLASTITE, SL, HHD
27	626-0013	ASSY, 90 DEG, .375 DOLE x.375 BARB - WITH 208-0010
	626-0012	ASSY, 90 DEG, .375 DOLE x.250 BARB - WITH 208-0010
KITS AVAILABLE		
	670-0012	PKG, INSTALL, 2 EA 3/8 x 3/8 90 DEG FITTINGS
	670-0014	PKG, INSTALL, 2 EA 3/8 x 1/4 90 DEG FITTINGS
	675-0005	KIT, MECHANICAL ORIFICE CONTROL

POST MIX VALVE ASSEMBLY

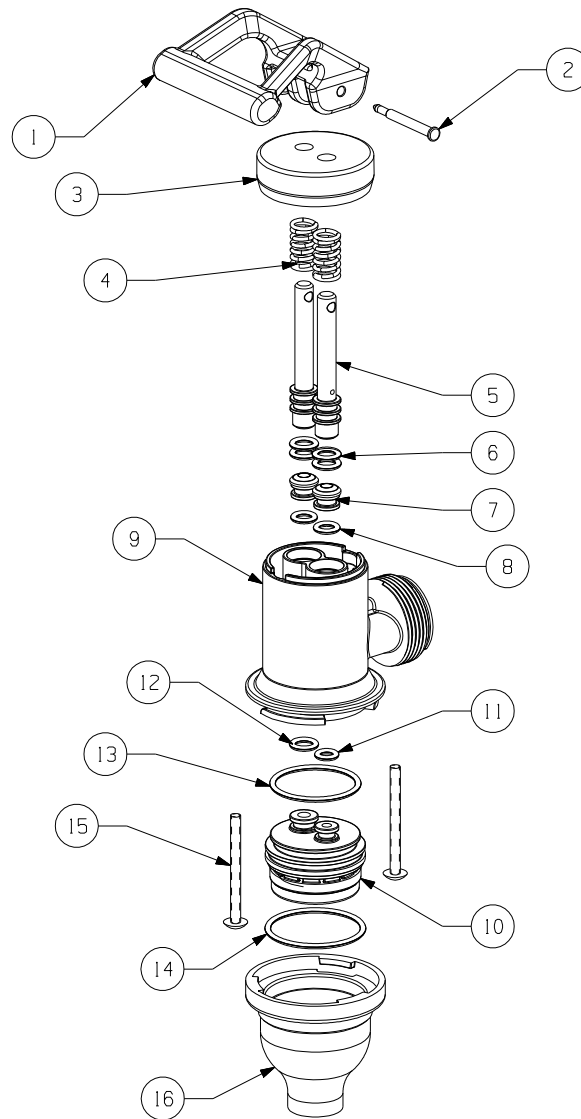

POSTMIX VALVE ASSEMBLY		
ITEM	SCHROEDER PN	DESCRIPTION
1	265-0551	HANDLE, ANGLED, NON-LOCK, POSTMIX VALVE
2	279-0076	RETAINER, PIN, PMV
3	631-0079	CAP ASSEMBLY, PMV
4	215-0008	SPRING, POSTMIX VALVE
5	625-0031	PISTON ASSY, POSTMIX VALVE - WITH 208-0010-429
6	208-0010-429	O-RING, 2-010, LUBRICATED
7	631-0080	VALVE SEAT ASSY, PMV - WITH 208-0009
8	208-0009	O-RING, 2-009
9	265-0279	BODY, VALVE, PMV
10	631-0069	NOZZLE ASSY, POSTMIX VALVE - WITH O-RINGS
11	208-0008	O-RING, 2-008
12	208-0010	O-RING, 2-010
13	208-0023	O-RING, 2-023
14	208-0025	O-RING, 2-025
15	220-0039	SCREW, 6-32 x 1.500, PH, THD, SS
16	265-0305	BODY, NOZZLE, POSTMIX, BLACK
	637-0005	ASSY, VALVE, POSTMIX

SHANK AND TUBE ASSEMBLY

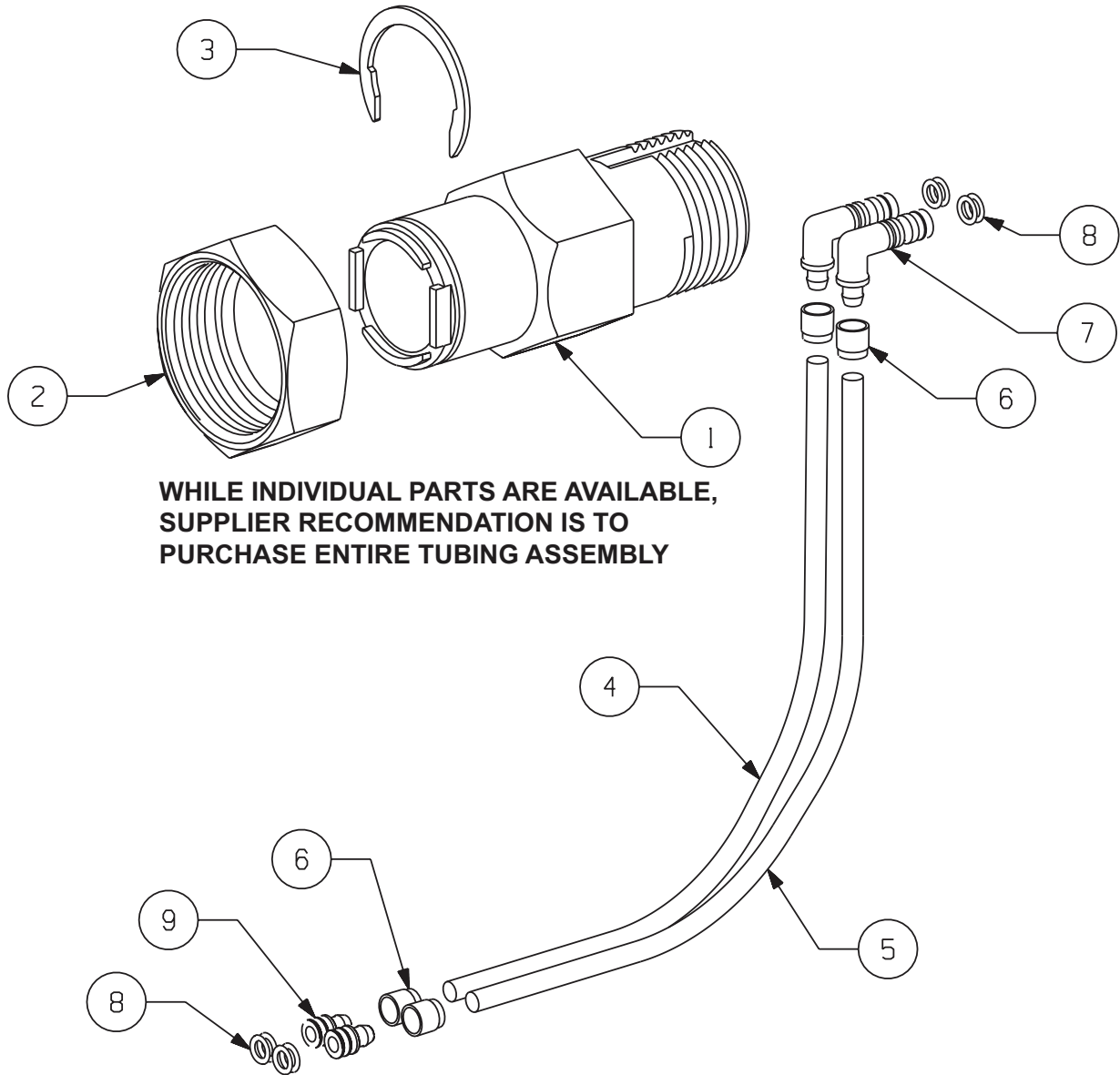

**WHILE INDIVIDUAL PARTS ARE AVAILABLE,
SUPPLIER RECOMMENDATION IS TO
PURCHASE ENTIRE TUBING ASSEMBLY**

TUBE ASSEMBLIES		
ITEM	SCHROEDER PN	DESCRIPTION
	632-0143	SUB-ASSY, WATER, PMV W/O ADA LEVER
	632-0144	SUB-ASSY, S1, PMV W/O ADA LEVER
	632-0113	SUB-ASSY, WATER, SQ URN, PMV
	632-0114	SUB-ASSY, S1, SQ URN, PMV
4	030-0029	TUBE, .218 x .032, WATER, PMV
5	030-0030	TUBE, .218 x .032, S1, PMV
6	265-0380	FERRULE, PMV
7	626-0005	FITTING ASSY, 90 DEG, PMV, W/ O-RING 208-0010-429
8	208-0010-429	O-RING, 2-010, LUBRICATED
9	626-0004	FITT ASSY, INLET, PMV, W/ O-RING 208-0010-429
		SHANK ASSEMBLY
	645-0173	SHANK ASSY, PMV
1	265-0376	SHANK, VALVE, PMV
2	265-0600	NUT, SHANK, PMV
3	248-0006	CLIP, TRUARC, .938